

Multi-Body Systems (Angled Surfaces)

1. A 15.0 kg block rests on a **frictionless** incline that makes an angle of 30.0° with the horizontal. The block is connected by a **light, inextensible rope** that passes over a **frictionless pulley** to a **25.0 kg** block hanging vertically on the other side.
 - a) Determine the **acceleration of the system** (magnitude and direction of motion of each mass).
 - b) Determine the **tension in the rope**.

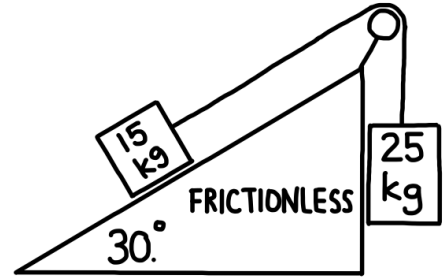

2. A **2.0 kg** block rests on a **40.0° incline**. The coefficient of **kinetic friction** between the block and the incline is $\mu = 0.35$. The block is connected by a **light, inextensible rope** that passes over a **frictionless pulley** to a **5.0 kg** block hanging vertically on the other side. Assume the system is released from rest.
 - a) **Determine the acceleration of the system.** State the direction of motion for each mass.
 - b) **Determine the tension in the rope.**

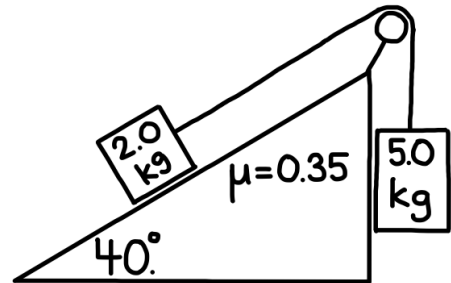

3. A **16 kg** block sits on a **25° incline**. The coefficient of **kinetic friction** between the block and the surface is $\mu = 0.65$. The block is attached by a **light, inextensible rope** that passes over a **frictionless pulley** to a **20 kg** block hanging vertically on the other side. The system is released from rest.
 - a. Determine the **acceleration of the system.** State the direction of motion of each mass.
 - b. Determine the **tension in the rope.**

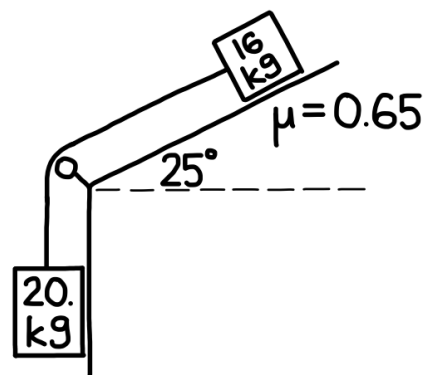

4. Two blocks of mass **4.0 kg** and **10.0 kg** rest on a **35° frictionless incline**. They are connected by a **light cord** along the incline. A **second cord** attaches the **10.0 kg block to a wall** at the top of the incline, preventing any motion. Both cords and the surface are assumed to be frictionless and massless.
- Determine the **tension in the cord between the 4.0 kg and 10.0 kg blocks**.
 - Determine the **tension in the cord connecting the 10.0 kg block to the wall**.

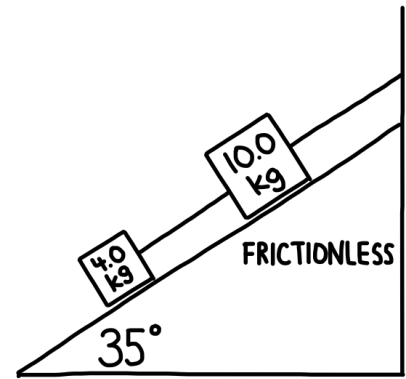

5. A **6.0 kg block** rests on a **20° incline**. The coefficient of **kinetic friction** between the block and the incline is $\mu = 0.70$. The block is attached by a **light, inextensible rope** that passes over a **frictionless pulley** to a **hanging mass m** on the other side. When the system is released, the **hanging mass accelerates downward at 2.9 m/s^2** .
- Determine the **mass m** .
 - Determine the **tension in the rope**.

