

More Forces at Angles

1. Determine the acceleration of the object of a 20 kg object being pushed with 200 N downwards at an angle of 40 degrees to the horizontal if the surface has a coefficient of kinetic friction of 0.40.
2. While setting up a display, you pull a 25 kg box with a rope that makes a 30° angle above the floor. The tension in the rope is 50 N and the coefficient of kinetic friction is 0.25.
 - a. Find the acceleration of the box.
 - b. Is it speeding up or slowing down?
3. A 12 kg box slides down a 25° ramp coated in wax ($\mu_k = 0.20$).
 - a. Determine its acceleration down the ramp.
 - b. Describe how the friction affects its motion.

4. A block is pushed up a **20° incline** with an **initial speed of 5.0 m/s**. The coefficient of **kinetic friction** between the block and the incline is $\mu = 0.40$. The block slides up the incline and eventually comes to rest. Determine the **distance the block travels up the incline** before stopping.

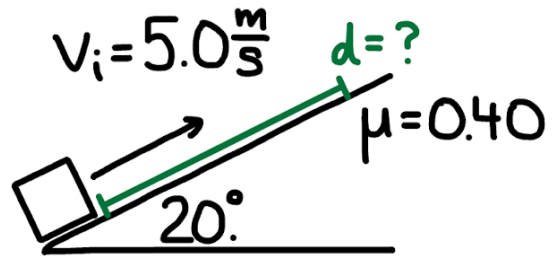

5. A **64 kg block** rests on a **horizontal surface** where the **coefficient of kinetic friction is $\mu = 0.35$** . A **450 N force** is applied to the block at an angle of **25° below the horizontal**, as shown. Determine the **acceleration of the block**.

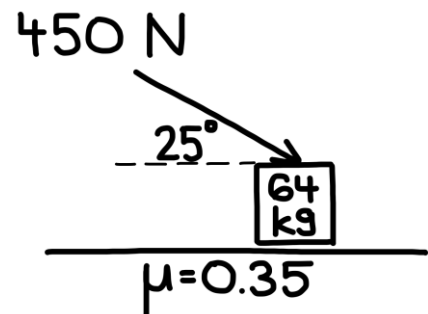

6. A **5.0 kg block** rests on a **horizontal surface** where the **coefficient of kinetic friction is $\mu = 0.55$** . A **45 N force** is applied to the block at an angle of **40° above the horizontal**, as shown. Determine the **acceleration of the block**.

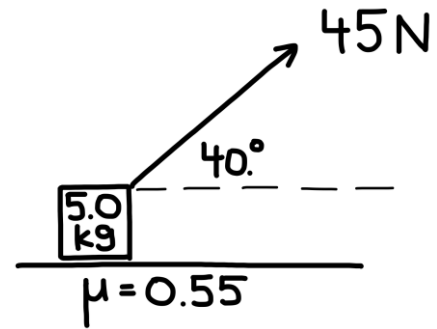

7. A **16 kg block** rests on a **20° incline** where the **coefficient of kinetic friction is $\mu = 0.40$** . A **150 N horizontal force** is applied to the block, pushing it **toward the incline**. Determine the **acceleration of the block** along the incline. (State whether it accelerates up or down the incline.)

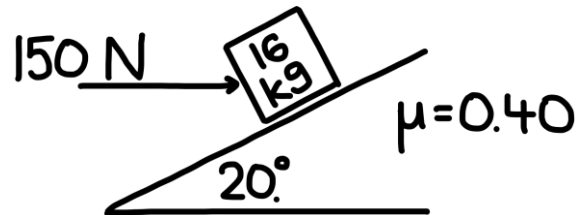

8. A **20 kg block** rests on a **horizontal surface** where the **coefficient of kinetic friction is $\mu = 0.40$** . A person pushes on the block, applying a **200 N force** at an angle of **40° below the horizontal**, as shown. Determine the **acceleration of the block**.

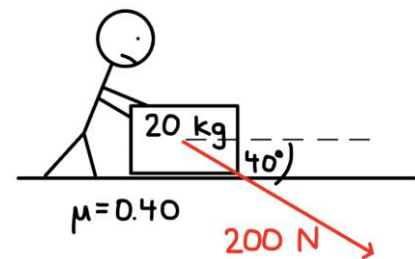

9. A block rests on a **20° incline**. When released, it accelerates **down the incline at 2.5 m/s^2** . Determine the **coefficient of kinetic friction** between the block and the incline.

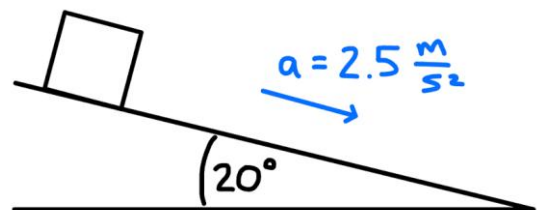

10. A **25 kg block** rests on a **horizontal surface**. The **coefficient of static friction** between the block and the surface is **$\mu_s = 0.55$** . A force is applied to the block at an angle of **35° above the horizontal**, as shown. Determine the **minimum force required to start moving the block**.

