

Free-Body Diagrams

Construct free body diagrams for the following situations for the following situations at the instant in time for which they are described. Be sure to label the forces according to type (F_A , F_F , F_N , F_T , F_S , F_g) and draw the arrows such that their length reflects the magnitude of the force.

- 1) A book is at rest on top of a table.
- 2) A book is being pushed to the right across a table surface with a constant velocity. (Neglect air friction)
- 3) A book is being pushed to the right across a table surface and is accelerating in the direction of the push. (Neglect air friction)
- 4) A gymnast is suspended from the ceiling by two ropes.
- 5) A student is pushing lightly upon a large box in an attempt to push it to the right across the floor but the box fails to move.
- 6) A box moving to the right (which was previously pushed) gradually slows to a stop.
- 7) A ball is dropped from rest from the top of a building. (Neglect air friction)
- 8) A football is being thrown upwards and rightwards.
- 9) Several seconds after being thrown, a football is moving upwards and rightwards towards the peak of its trajectory. (Neglect air friction)
- 10) Several seconds after being thrown, a football reaches the peak of its trajectory. (Neglect air friction)
- 11) A falling skydiver is speeding up.
- 12) A falling skydiver has reached terminal velocity.
- 13) After reaching terminal velocity, a falling skydiver has opened her parachute.
- 14) A car is moving to the right at a high speed across a level roadway; the driver's foot remains on the gas pedal.
- 15) A car is skidding to a stop (with wheels locked) while travelling to the right across a level roadway.
- 16) A picture hangs by two wires oriented at angles to the vertical.

Net Force

Determine the net force. Be sure to indicate both the magnitude and direction.

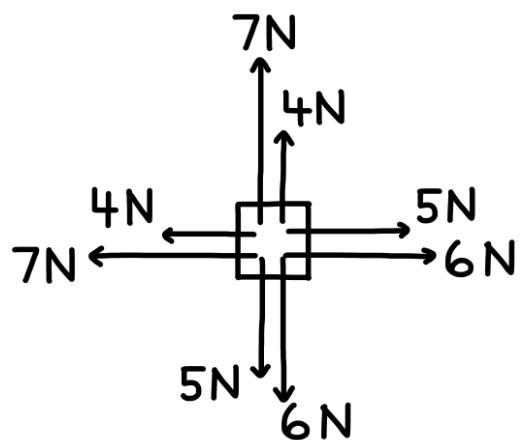
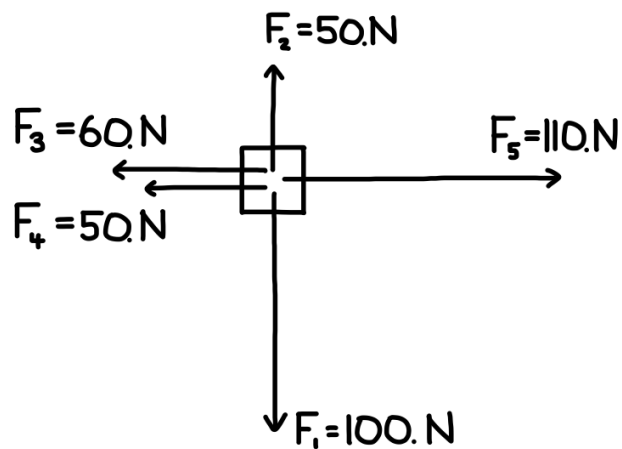
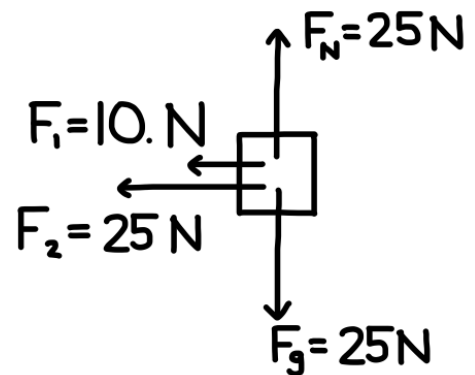
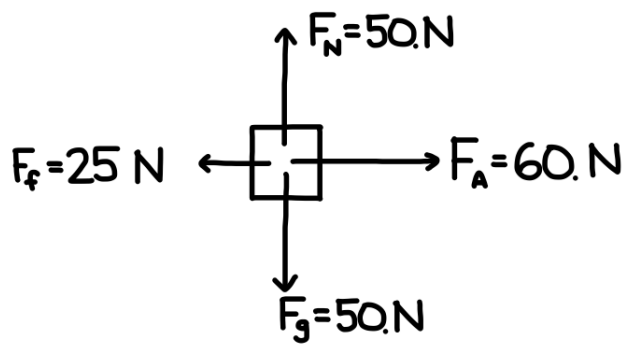
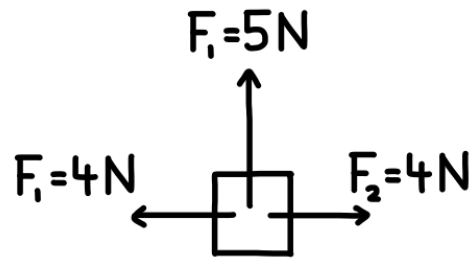
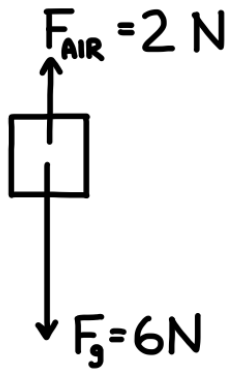

Determine the unknown force.

a) $F_{\text{net}} = 3 \text{ N Right}$

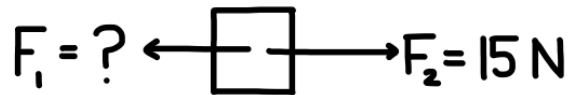

d) $F_{\text{net}} = 10. \text{ N Right}$

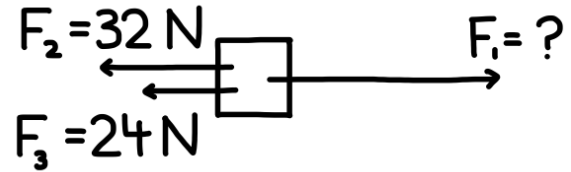

b) $F_{\text{net}} = 10. \text{ N Down}$

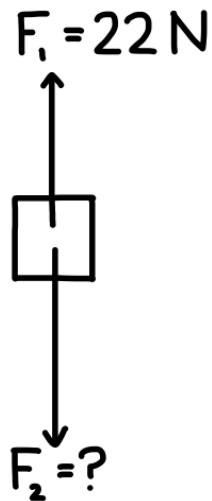

e) $F_{\text{net}} = 0$

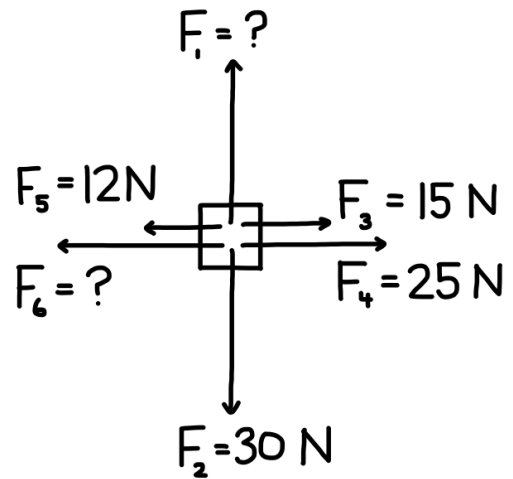

c) $F_{\text{net}} = 12 \text{ N Up}$

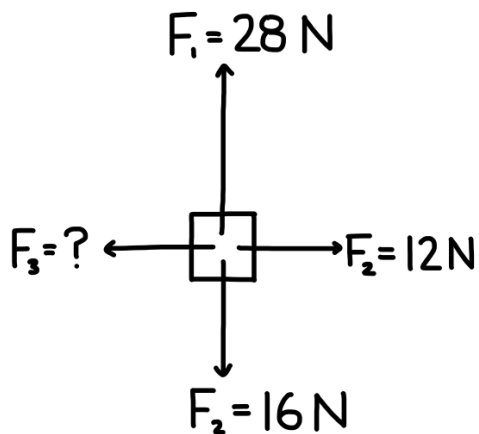

f) $F_{\text{net}} = 2 \text{ N Right}$ (add vectors as needed)



Determine the unknown force.

1 Draw a clear **free-body diagram** showing all forces.

2 Identify the **vertical and horizontal** forces.

3 Find the **unknown force's magnitude**.

1. A book rests on a table. The downward force of gravity on the book is **15 N**. What is the upward normal force acting on the book?
2. A textbook is pushed across a table with a **3.0 N** horizontal force. It moves at a constant speed. What is the frictional force acting on the book?
3. Two students pull on opposite ends of a rope. One pulls with **65 N**, and the rope does not move. What is the force applied by the other student?
4. A lamp hangs motionless from a ceiling by a cord. The lamp's weight is **48 N** downward. What is the tension in the cord?
5. A student pushes sideways on a box with **25 N**, but the box does not move. What is the static frictional force on the box?
6. A box rests on a table. The table pushes upward on the box with **40 N** of force. What is the downward gravitational force on the box?
7. A gym bag hangs from the ceiling by two identical **vertical straps**. The total downward force on the bag is **90 N**. How much force does each strap support?
8. A student stands still on a floor. The floor pushes up on the student with a **600 N** normal force. What is the downward gravitational force acting on the student?
9. A box is pushed to the right with **20 N** and pulled to the left with an unknown force. The box does not move. What is the leftward force acting on the box?
10. A sandbag rests on the floor of a stationary lift. The total upward tension in the lift cable is **3000 N**. The lift itself weighs **2800 N**, and the sandbag pushes down on the lift floor with an unknown force. What is the upward force exerted by the lift floor on the sandbag?